

# Refrigerated Type Air Dryer Operation Manual for Option

## Applicable model

**IDU22E-30-T**

**IDU37E-30-T**

- This manual is applied to the option T of applicable models.
- For other options, refer to the Operation Manuals corresponding to the symbol of required option.
- For the parts not specific for the option in this manual, refer to the Operation Manual of standard specification.

### 1. Specifications of options

- 1) With the terminal for run signal and alarm signal
  - The run signal and the alarm signal are output by the non-voltage contact.
    - Running . . . . . When the product is operating; Close
    - Alarm . . . . . When the product stops due to failure; Close
  - Contact capacity
    - Run signal , Alarm signal . . . . . AC250V, 7A
  - Minimum current: 24V, 1mA (AC/DC) for both of run and error signals

### 2. Remote operation

- For the remote operation, turn on and off the power supply side under the condition of the Switch with Lamp ON.
- Ensure at least 3 minutes is left after the unit is stopped before restarting it, even for the remote operation. If the product is restarted within less than 3 min. protective equipment (overload relay) may activate and prevent the product from restarting. Additionally, the frequency to start and stop the operation must be restricted to 5 times per hour (to prevent breakage of the motor).

### 3. How to connect the power supply

Connect the power cable and signal cable in the following procedures.

- 1) Take off the front panel.
- 2) Insert the power cable prepared by the customer into the power cable inlet (with rubber grommet) and bring the power cable near the terminal block through the base hole.
- 3) Connect the ground line.
- 4) Insert the signal cable prepared by the customer into the signal cable inlet (with rubber grommet) and bring the signal cable near the terminal block.
- 5) Connect the signal cable to the terminal of the GFCI.
- 6) Mount the front panel.

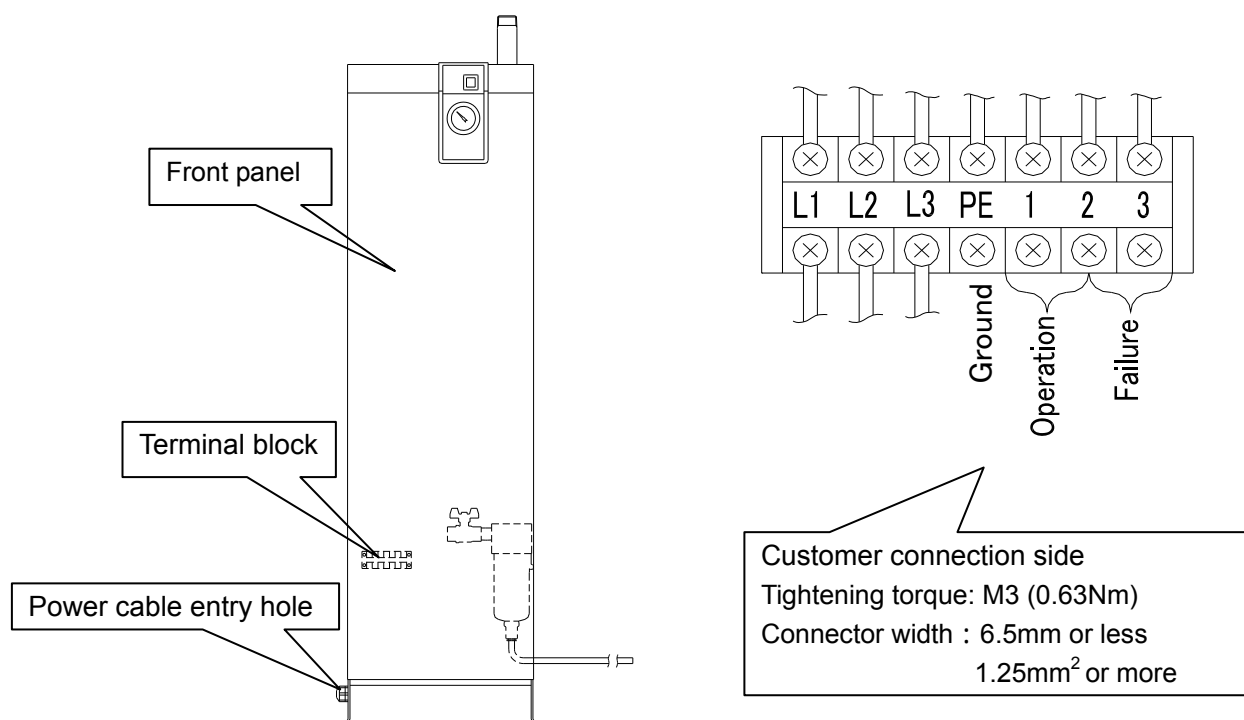

#### 4. How to reset the alarm

The output of the alarm can be stopped by turning off the Switch with lamp. Remove the cause of alarm operation and leave it for 3 minutes or longer after the stopping the operation, and turn on the Switch with lamp to re-start.

The thermal relay is still in operation if the output of the alarm is not stopped even after the Switch with lamp is turned off. Refer to “5-2. How to reset the thermal relay and high pressure switch” in the operation manual of the standard product, and reset it.

#### 5. Electric circuit

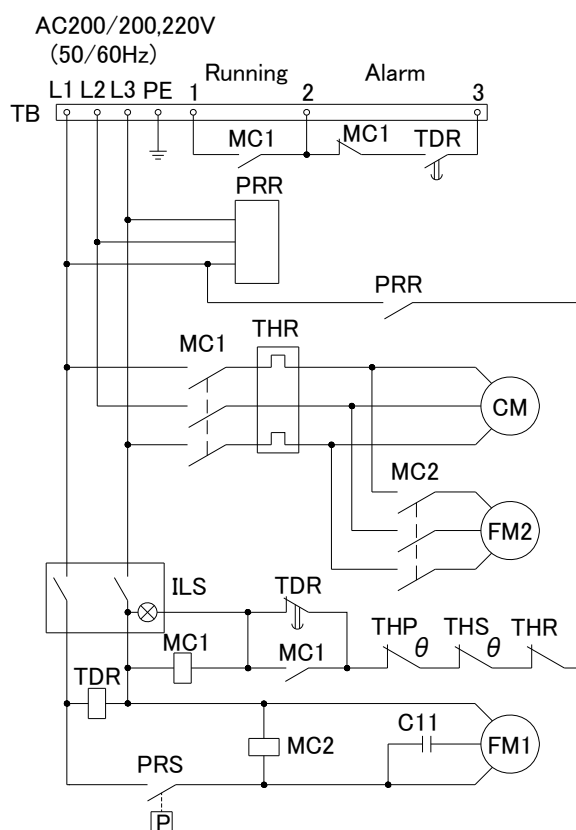

SYMBOL	DESCRIPTION
CM	Compressor Motor
FM1,2	Fan Motor
MC1,2	Magnetic Contactor
PRS	Pressure Switch
ILS	Switch with Lamp
THR	Thermal Relay
C11	Capacitor For Running Fan Motor
TB	Terminal Block
PRR	Phase Reversal Relay
THS	Thermostat
THP	Thermal Protector
TDR	Time Delay Relay